

12 11 10 9 8 7 6 5 4 3 2 1

Glass Sizes

W = Glass Width (Max. 908mm)
 L = Glass Height
 H = Opening Height

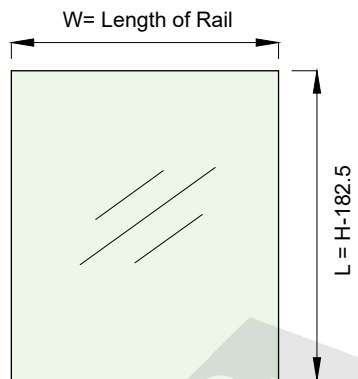

TOP RAIL'S INSTALLATION

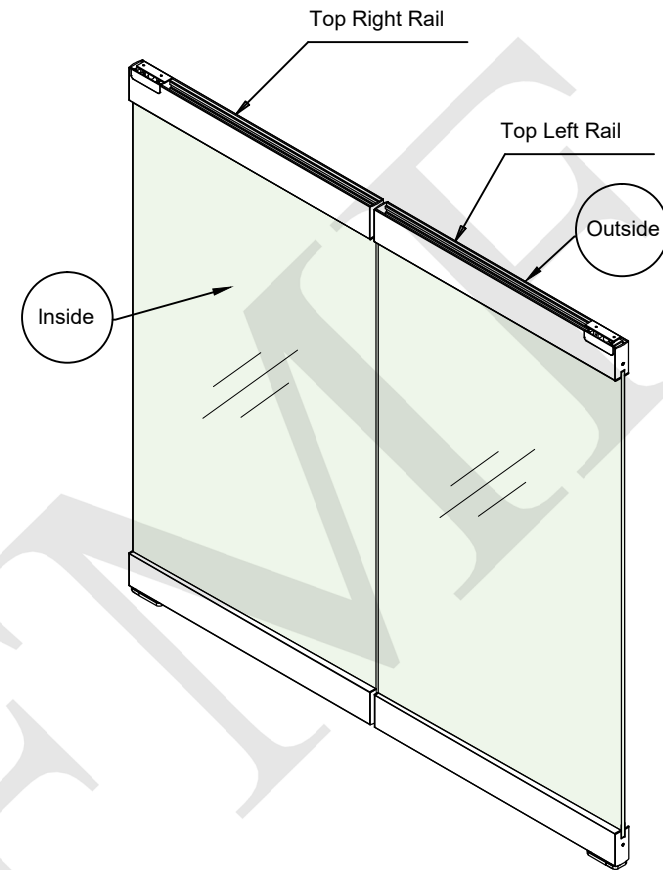
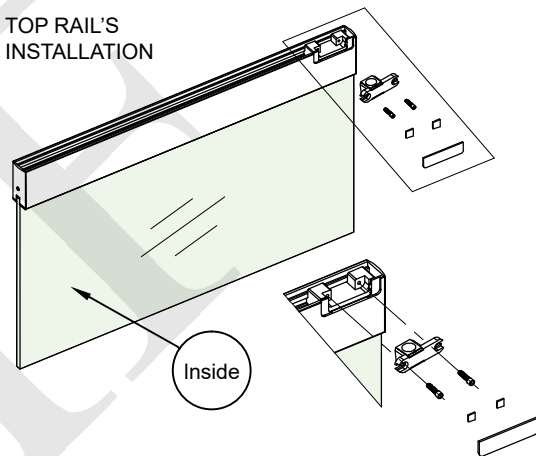

TOP RAIL'S INSTALLATION TO THE TOP DRUM PIN (PAT-PIN)

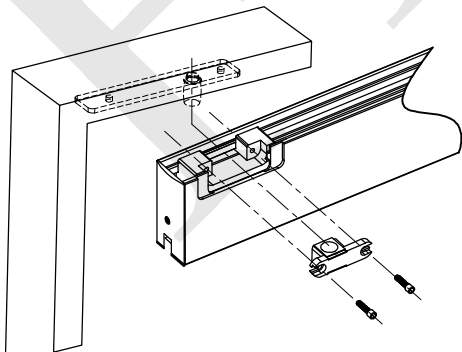

TOP RAIL'S INSTALLATION ON THE GLASS DOOR

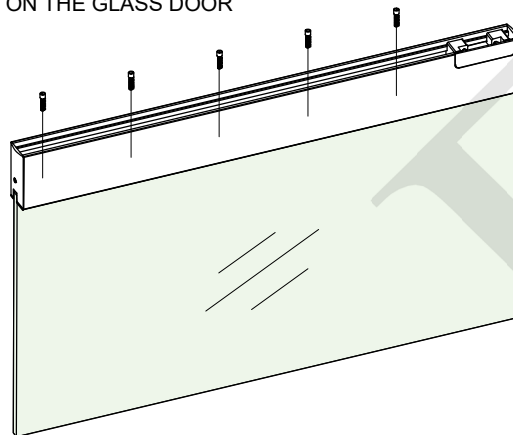

NOTES:

- PROPRIETARY AND CONFIDENTIAL
 - THE INFORMATION CONTAINED IN THIS DRAWING IS THE SOLE PROPERTY OF FMF GLASS HARDWARE. ANY REPRODUCTION IN PART OR AS A WHOLE WITHOUT THE WRITTEN PERMISSION OF FMF GLASS HARDWARE IS PROHIBITED.

PRODUCT NAME:

Top Door Rail

PRODUCT MODEL NUMBER:

TOP-RL01, TOP-RR01

DWG NO.

TOP-R_1

UNIT:

MM

DWG SIZE/SCALE

A4/NTS

FMF GLASS HARDWARE

REV.

1

DATE:

04.24

DRAWN BY:

FMF

SHEET 1 OF 1

12 11 10 9 8 7 6 5 4 3 2 1

H
G
F
E
D
C
B
A

H
G
F
E
D
C
B
A

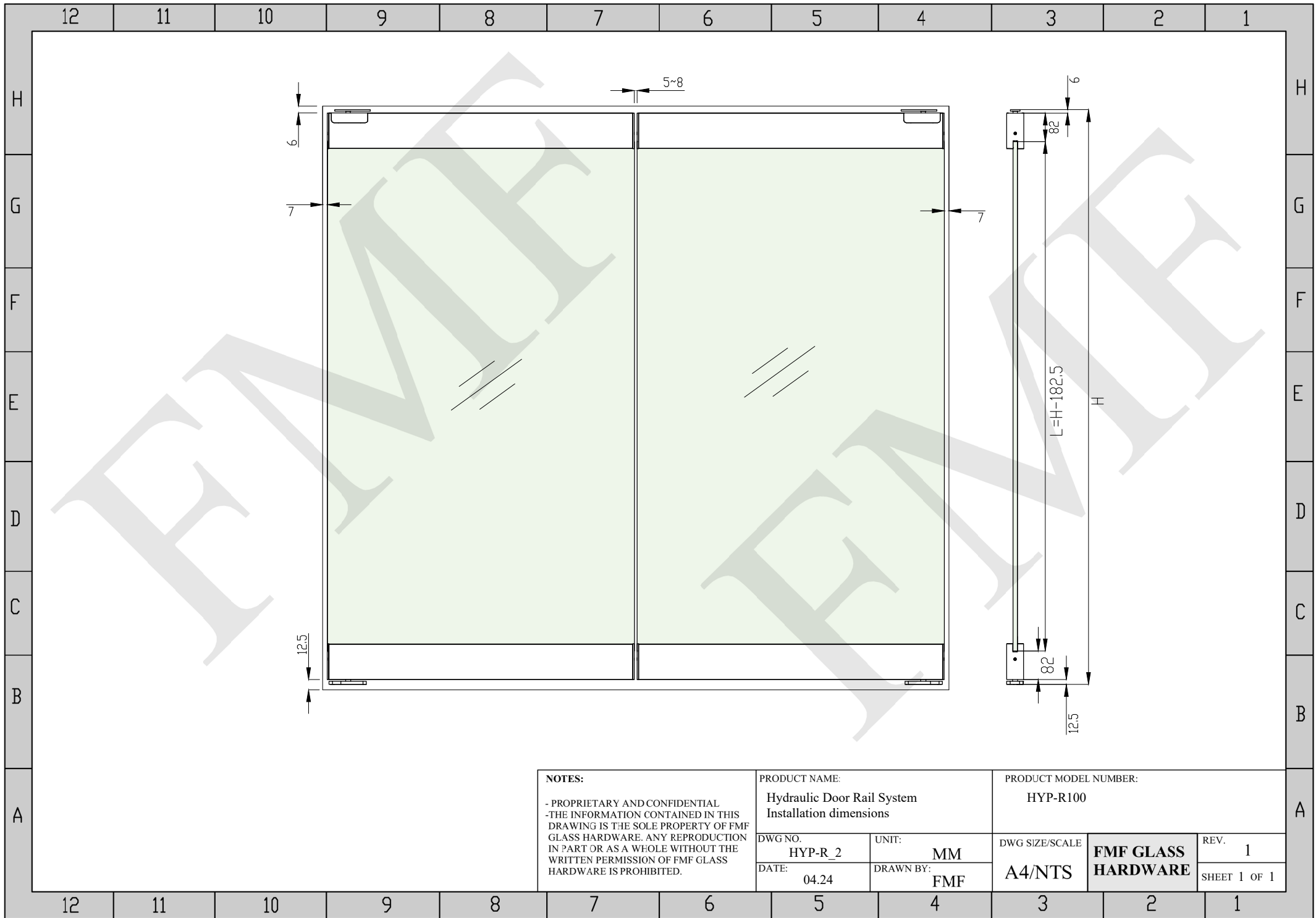

NOTES:
 - PROPRIETARY AND CONFIDENTIAL
 - THE INFORMATION CONTAINED IN THIS DRAWING IS THE SOLE PROPERTY OF FMF GLASS HARDWARE. ANY REPRODUCTION IN PART OR AS A WHOLE WITHOUT THE WRITTEN PERMISSION OF FMF GLASS HARDWARE IS PROHIBITED.

PRODUCT NAME:
 Hydraulic Door Rail System
 Installation dimensions

DWG NO. HYP-R_2	UNIT: MM
DATE: 04.24	DRAWN BY: FMF

PRODUCT MODEL NUMBER:
 HYP-R100

DWG SIZE/SCALE A4/NTS	FMF GLASS HARDWARE	REV. 1
		SHEET 1 OF 1