

12 11 10 9 8 7 6 5 4 3 2 1

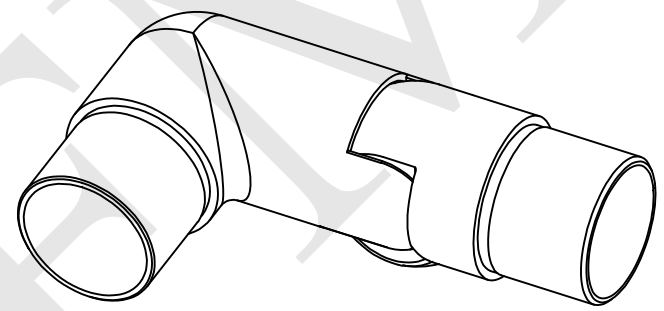
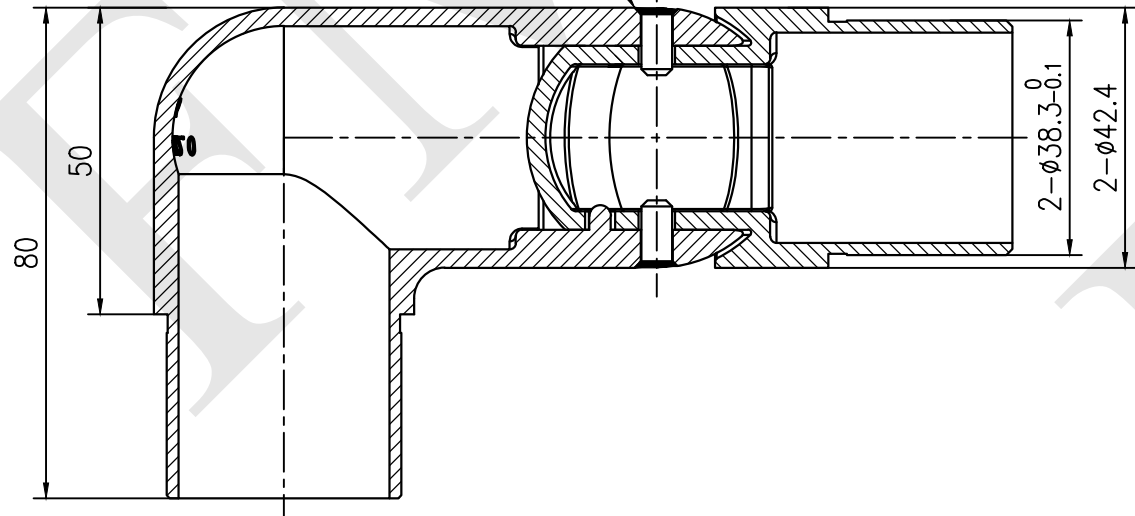
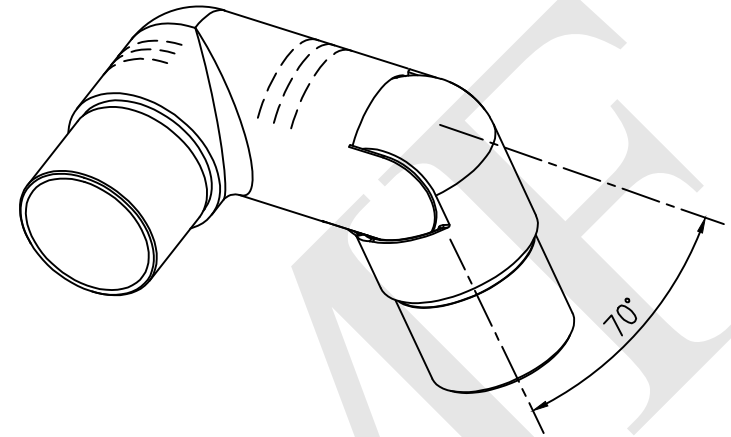
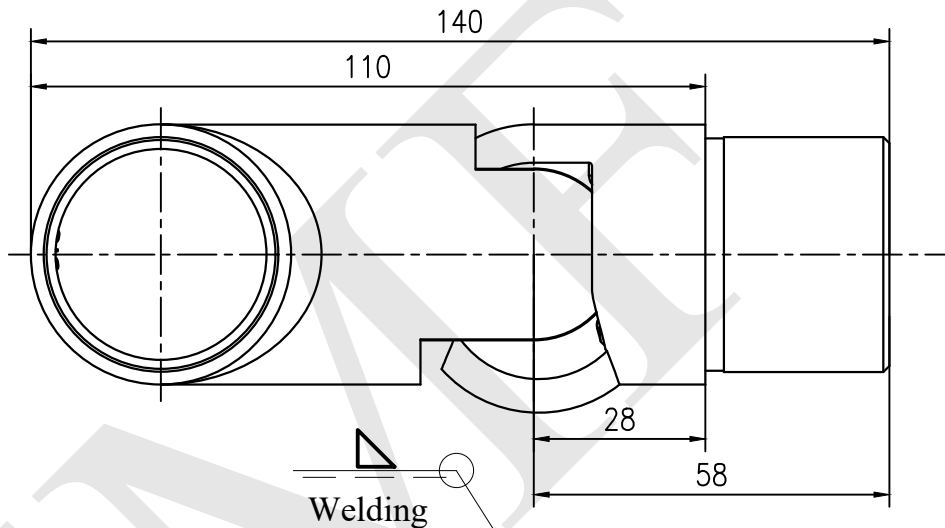

NOTES: - PROPRIETARY AND CONFIDENTIAL - THE INFORMATION CONTAINED IN THIS DRAWING IS THE SOLE PROPERTY OF FMF GLASS HARDWARE. ANY REPRODUCTION IN PART OR AS A WHOLE WITHOUT THE WRITTEN PERMISSION OF FMF GLASS HARDWARE IS PROHIBITED.	PRODUCT NAME: 110-180° Adjustable Handrail Elbow Connector Right Corner		PRODUCT MODEL NUMBER: 110ELB-R424		
	DWG NO. 110ELB-R424_1	UNIT: MM	DWG SIZE/SCALE	FMF GLASS HARDWARE	REV. 1
	DATE: 11.22	DRAWN BY: FMF	A4/NTS		SHEET 1 OF 1

12 11 10 9 8 7 6 5 4 3 2 1